

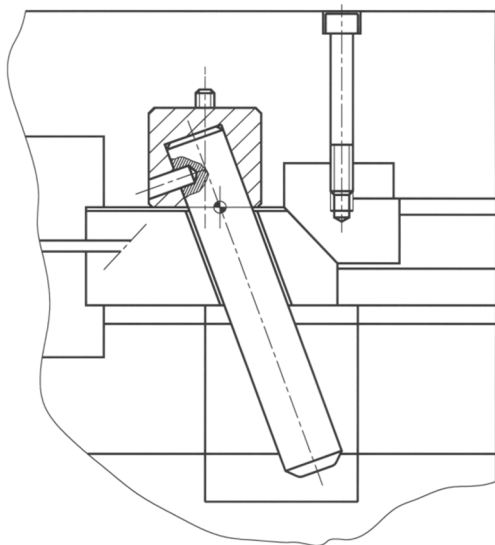

## INCLINED ASSEMBLY

### PRODUCT DESCRIPTION



During the years of experience in the injection mould sector mechanizations, we have detected the need of products which are able to agilize its mechanization; because of this fact, and given the complexity of making the tilted pillars in moulds, we have decided to manufacture these tilted assemblies.

Our standard system allows us to have in stock and ready for immediate delivery an amount of 140 models, with which we expect to greatly cover the existing needs.

The assembly consists of a support in 1.2312 material screwed into the allocation previously made in the mould plate with 2 conical screws fixing and aligning the position of the tilted pillar out of the support. Also, their nickel-terflon coating ensures easier disadjustment through pressure.

Mounting and unmounting operations are made through the front side of the plate, which makes it easy to exchange, when needed. The allocations to make on plates are always straight, so improving its mechanization agility. By using the BOLEXP tilted assembly, we keep free the down side of the plate through which we can make cooling circuits without interferences.

### FEATURES

The support material is a chromium, manganese and molybdenum low-alloy steel. Besides, a maximum of a tenth part of sulphur is added for improved machinability. This steel has good resistance to indentation and uniform hardness in all sizes:

#### **1.2312/40CrMnMoS8-6**

%	C	Mn	Si	P ≤	S	Cr	Mo	V	Ni	Other
min.	0.35	1.40	0.30	-	0.05	1.8	0.15	-	-	-
max.	0.45	1.60	0.50	0.03	0.1	2.0	0.25	-	-	-
Tensile strength Rm N/mm <sup>2</sup>										800 - 1100
Yield strength Rp0,2 N/mm <sup>2</sup>										750-950
Modulus of elasticity N/mm <sup>2</sup>										200,000
Rockwell Hardness HRC										29-34

On the pillar, a Ni-Cr cementation steel is used for the manufacturing of pieces requiring high mechanical responsibility in the core, as well as high tenacity and resistance to wear. It is used in cemented pieces, in general, of medium-high thickness and high responsibility, requiring good tenacity and resistance in the core and/or good resistance to compression.

### 1. 5732 /14NiCr10

%	C	Mn	Si	P ≤	S ≤	Cr	Mo	V	Ni	Other
min.	0.10	0.30	0.10	-	-	0.50	-	-	2.25	-
max.	0.15	0.60	0.35	0.040	0.040	0.80	-	-	3.00	-
Tensile strength Rm N/mm <sup>2</sup>									900-1200	
Yield strength Rp0.2 N/mm <sup>2</sup>									350-550	
Modulus of elasticity N/mm <sup>2</sup>									200.000	
Rockwell Hardness HRC									58-60	